

Kraftstoff Ø8
Fuel connections Ø8

Seewasser Ein Ø3/4"
Sea water In Ø3/4"

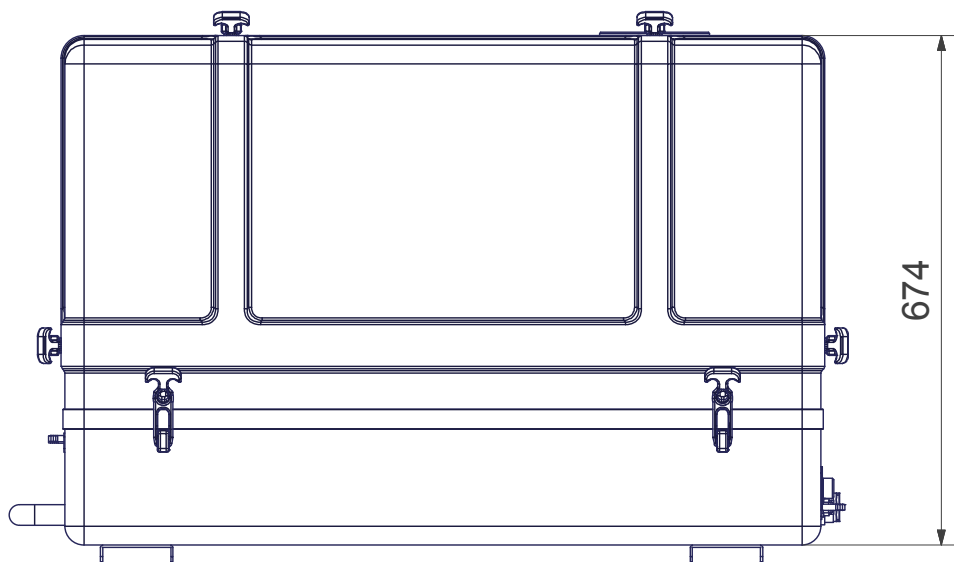

674

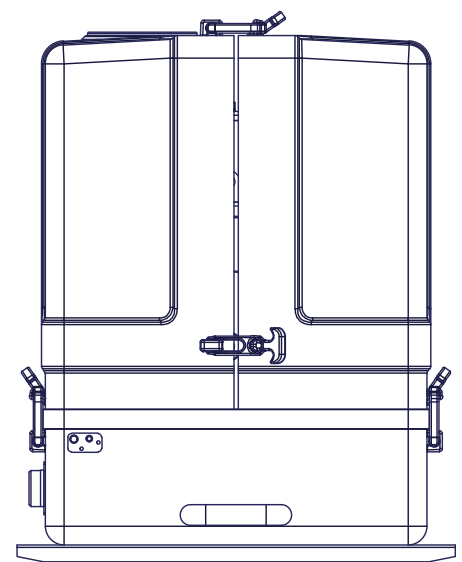

Abgas Ø50 / 1 1/2"
Exhaust Ø50 / 1 1/2"

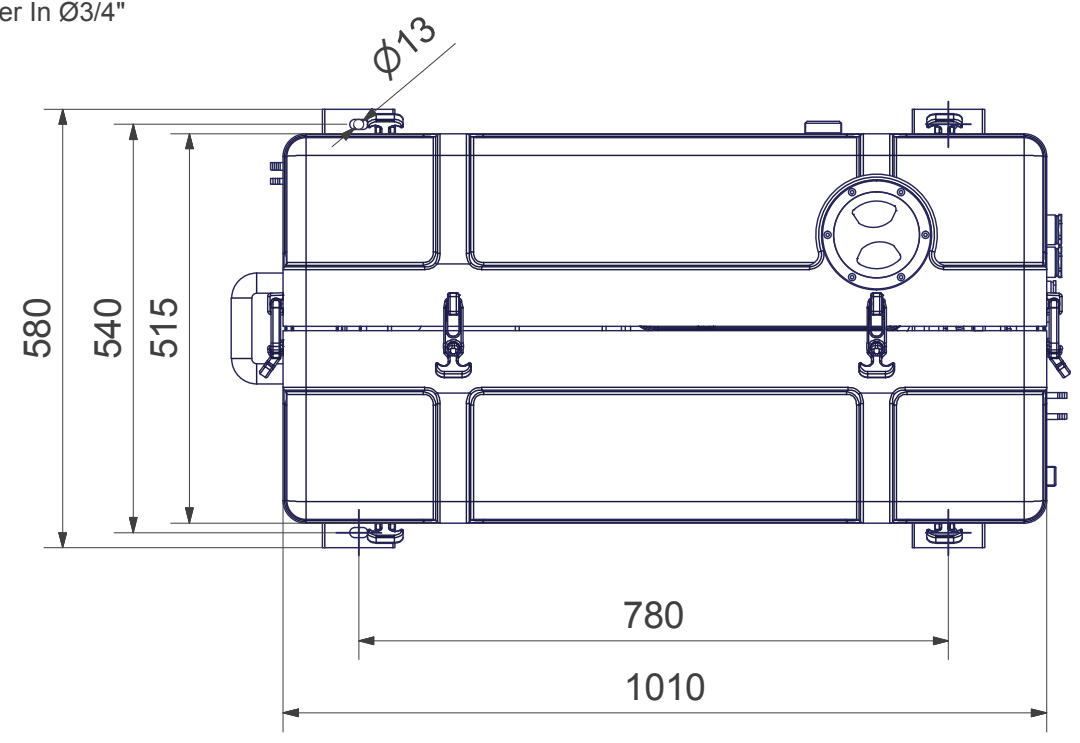
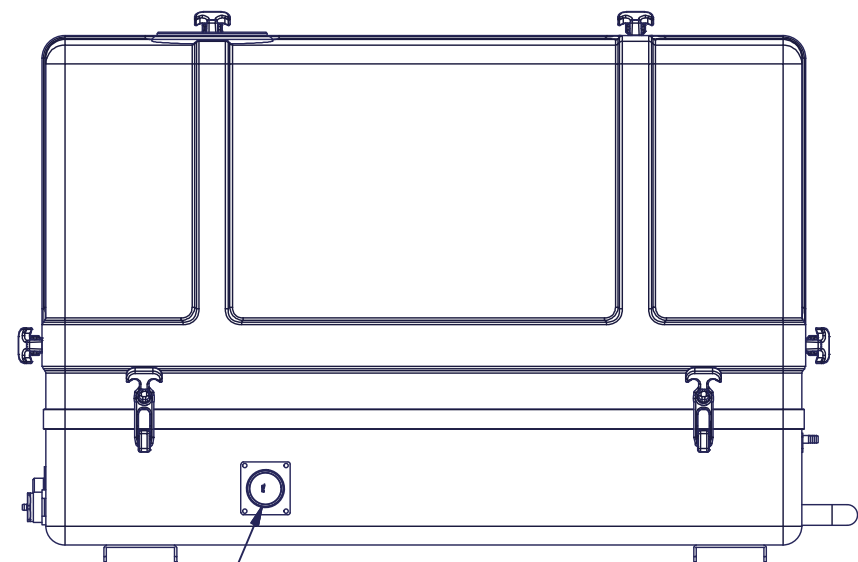

580

540

515

Ø13

780

1010

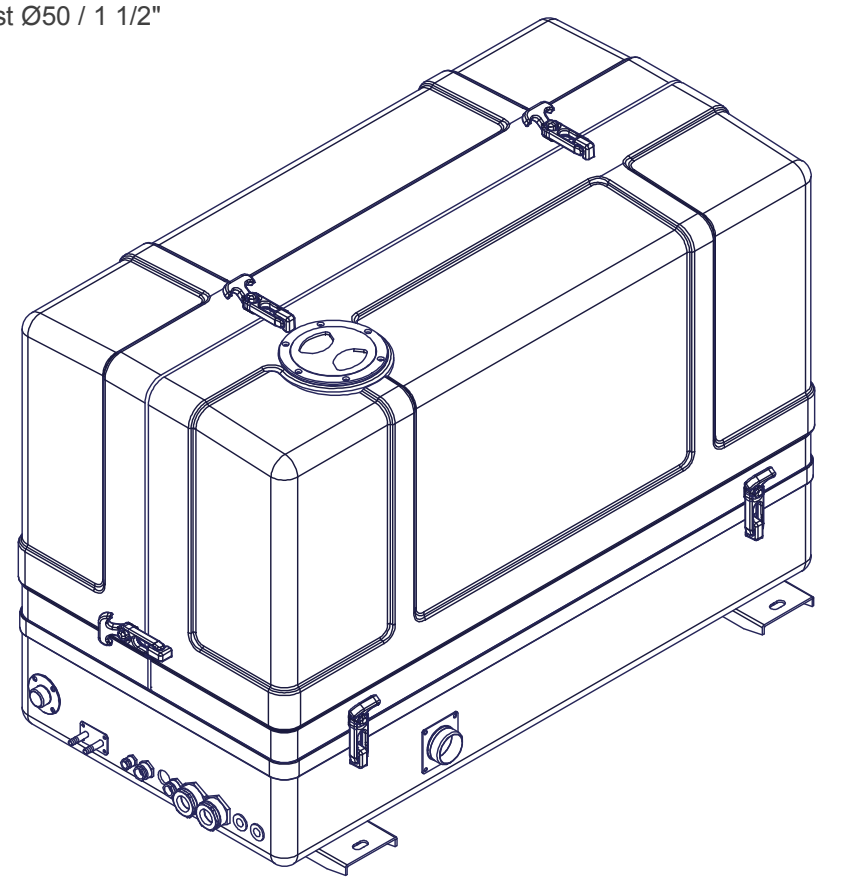

Verkaufsunterlagen, Änderungen vorbehalten

Fischer Panda [®]				Maßstab: 1 : 10		Gewicht: 355.000 kg		
				Material:		3D-Nr: FP2-011722		
Fischer Panda GmbH Otto-Hahn-Str. 40 D-33104 Paderborn Tel.: 05254/9202-0 Fax (05254) 9202-550 info@fischerpanda.de www.fischerpanda.de				Art.-Nr.: 01.01.01.110P		Vers.:		
				P24 PMS GFK 3D 230V 50Hz				
			Datum	Name				
			Bearbeiter	24.06.2013	jschaefers			
			letzte Freigabe					
			erste Freigabe					
			Allgemeintoleranzen nach DIN ISO 2768-mk Schutzvermerk nach DIN 34 beachten !					
Zust.	Änderungen	Datum	Name	PrL:	Zeichnungs Nr. FP1-029557		Version	Blatt 1 / 1 A3

